

PLEASE READ this guide prior to installation, to familiarise yourself with the various stages of construction required. Carefully open the pack and check the contents against the parts and fittings check list.

Do not destroy any of the packaging until you are certain that you have all the necessary parts. Please ensure that the packaging is disposed of in a safe and environmentally friendly way.

In the unlikely event of missing or damaged parts, please email hello@time4sleep.co.uk Please have this guide close at hand, quoting the part code reference numbers shown, when requesting spare or replacement parts.

Warnings

- This product should only be used on a firm and level floor with the anti-tilt devices (p) fitted, see Stage 13. Make sure the legs/base always remains in contact with the floor.
- Keep small parts out of the reach of children during assembly to prevent choking.
- DO NOT use power tools to construct this product.
- DO NOT tighten screws until parts are assembled or as advised in this guide.
- DO NOT over tighten screws or bolts.
- DO NOT use this product if parts are missing, damaged or worn.
- DO NOT sit or stand on the product.

Care Information

- To clean, wipe with a damp cloth.
- Never use scourers, abrasives or chemical cleaners.
- Do not use solvent based cleaners or detergents as they can bleach or damage the product.

Parts Identification

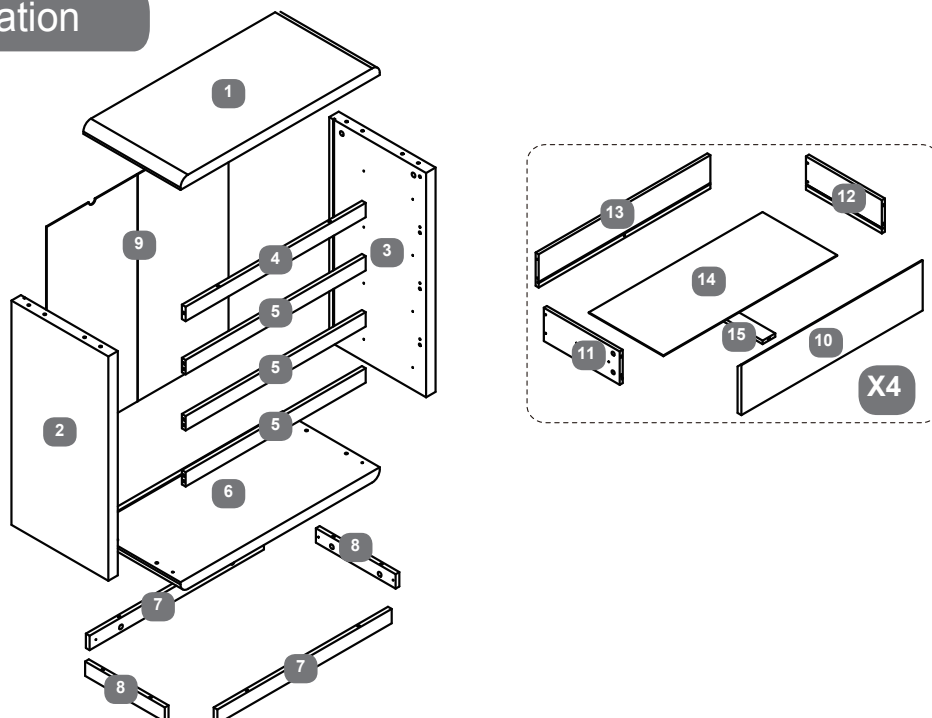









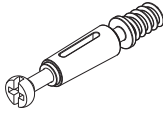
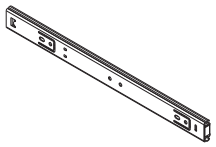

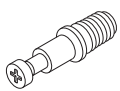

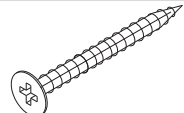

Parts Checklist

PACK	1/2	Qty	PACK	2/2	Qty
1	Top Panel	1	9	Back Panel	1
2	Left Side Panel	1	10	Drawer Front Panel	4
3	Right Side Panel	1	11	Drawer Left Side Panel	4
4	Upper Cross Rail	1	12	Drawer Right Side Panel	4
5	Drawer Cross Rail	3	13	Drawer Back Panel	4
6	Bottom Panel	1	14	Drawer Base	1
7	Base Frame - Long Plinth	2	15	Drawer Base Support Bar	1
8	Base Frame - Short Plinth	2			

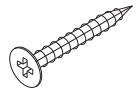
Fittings Checklist

HARDWARE NEEDED FOR CABINET ASSEMBLY

Code	Description	Qty	Code	Description	Qty
a	Metal Cam Dowel (Ø 7 x 40mm)	 x20	m	Two part drawer slide m1 & m2	 x8
b	Cam Lock (Ø 15 x 12mm)	 x20	n	Plastic bracket	 x4
c	Thin Thread Metal Cam Dowel (Ø 5 x 34mm)	 x20	p	Metal anti-tilt L bracket	 x2
d	Cam Lock (Ø 12 x 10mm)	 x20	q	Expanding wall plug	 x2
e	Wooden Dowel (Ø 8 x 30mm)	 x16	r	Screw (Ø 3 x 16 mm)	 x10
f	Screw (Ø 5 x 60 mm)	 x4	s	Back panel support fitting	 x10
g	Screw (Ø 4 x 35 mm)	 x22			
h	Screw (Ø 3.5 x 12 mm)	 x48			
j	Screw (Ø 4 x 14 mm)	 x8			
k	Screw (Ø 4 x 12 mm)	 x2			
l	Foot pad (Ø 12 x 5 mm)	 x6			

Additional Tools Required

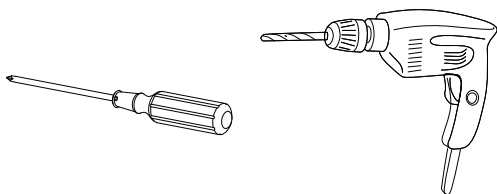

General Hints & Tips



Please retain your assembly instruction and tools provided for future use. Periodically check that all bolts are still tight.

Assembly requires two persons.

Care & Maintenance

In the unlikely event of missing or damaged parts, please contact your retailer. Please have this guide at hand quoting the part code reference numbers shown when requesting spare or replacement parts.



Approximate time to assemble this product

General Information

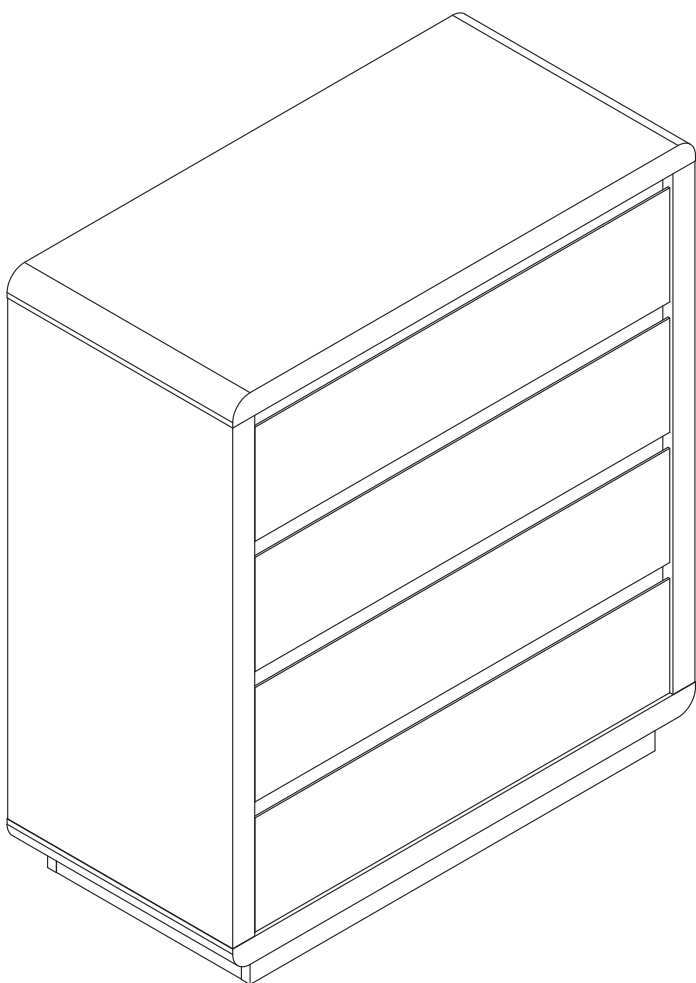

- This product is designed to hold 25Kg in total, spread evenly over the whole unit.
- Do not exceed this weight.
- We recommend that this unit is assembled in the room intended for use.
- When you are ready to start, make sure that you have the right tools, plenty of space and a clean, dry area for assembly.
- Unwrap all packaging materials and place the components on top of the carton box or on a clean floor to prevent them from scratching.
- Check the pack and make sure you have all the parts listed.
- Ensure that this product is fully assembled as illustrated before use.
- Check all screws or bolts are tightened and inspect regularly
- Tools not included unless they are specified in the parts list.

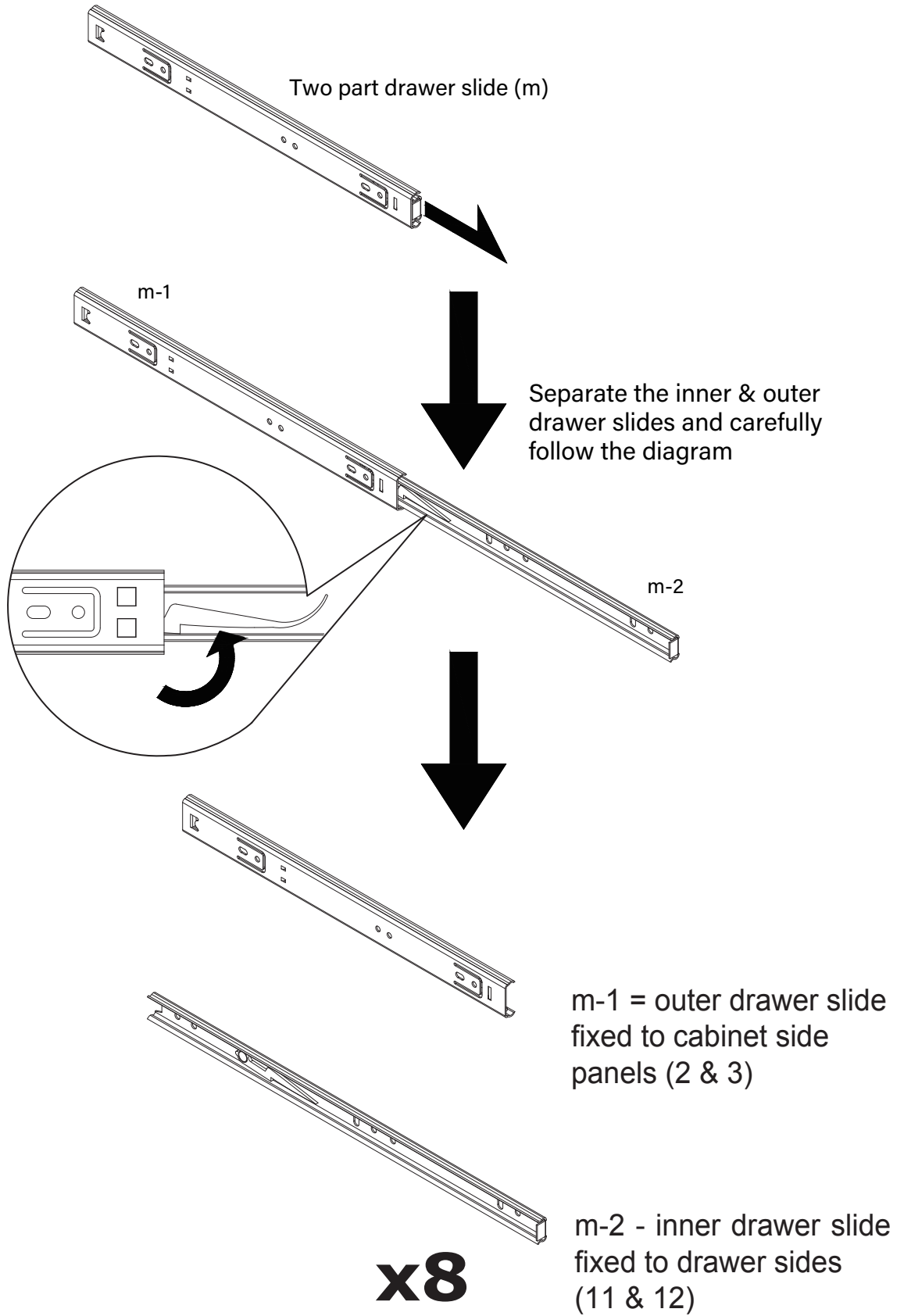





Cabinet Assembly

Stage
2

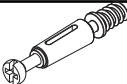
outer drawer slide (m-1)



a		3	
h		8	
m-1		4	

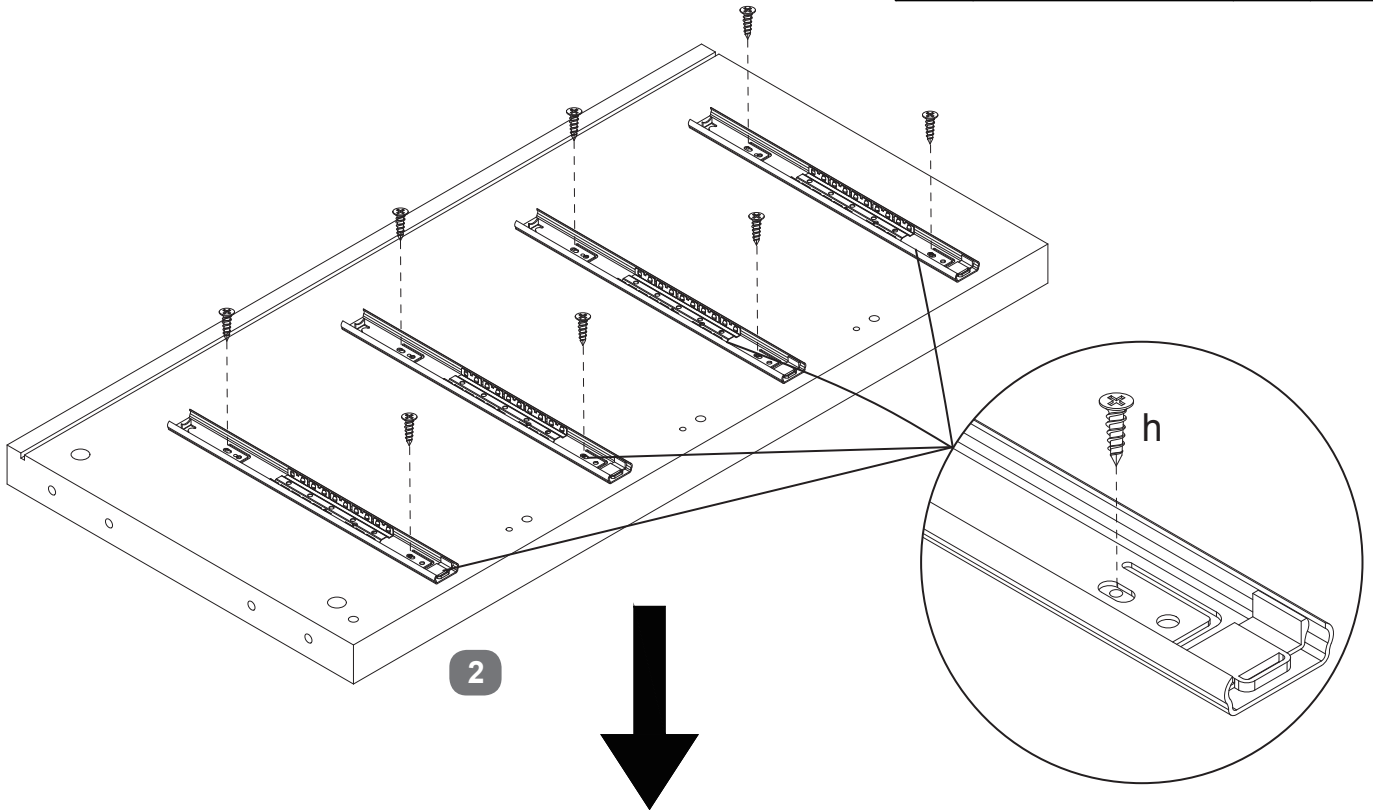

2

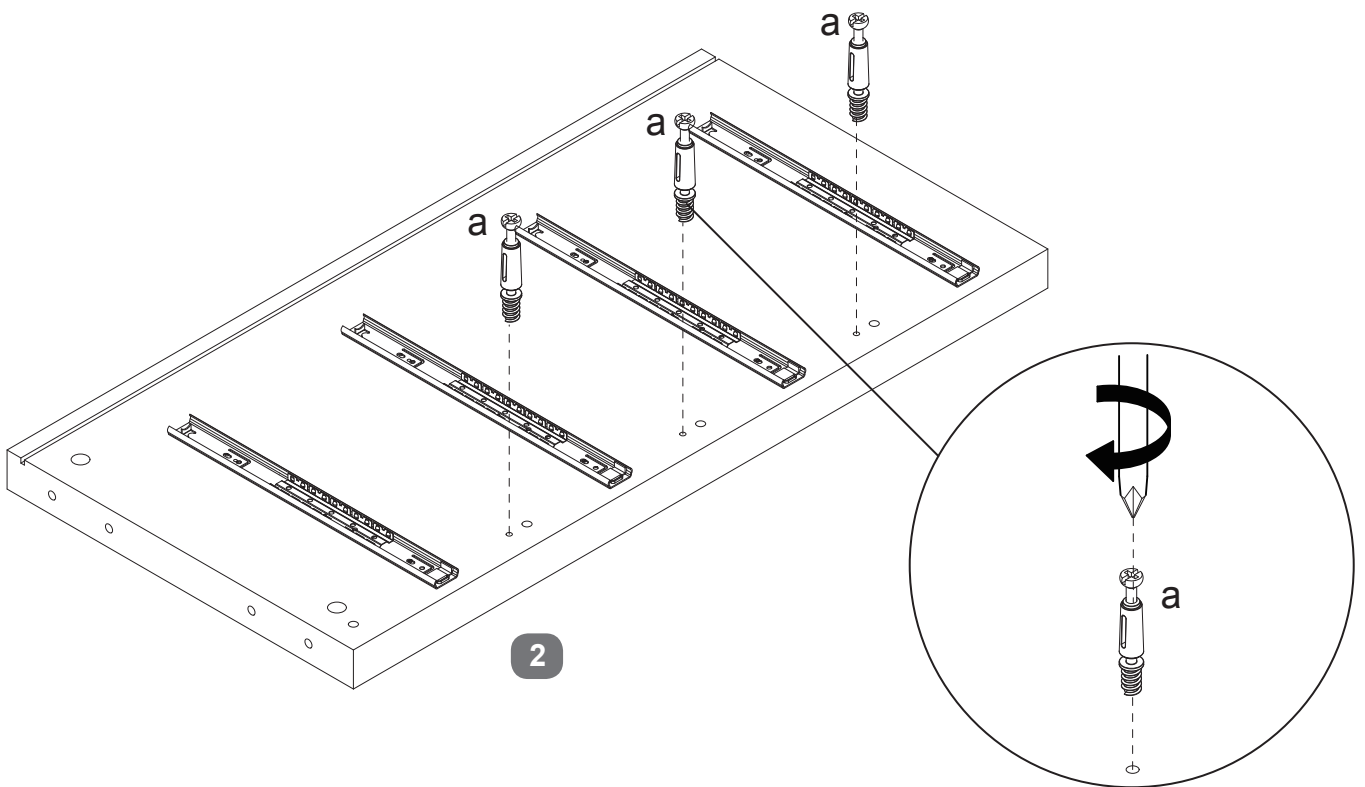

2

Cabinet Assembly

Stage
3

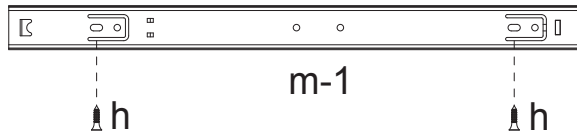

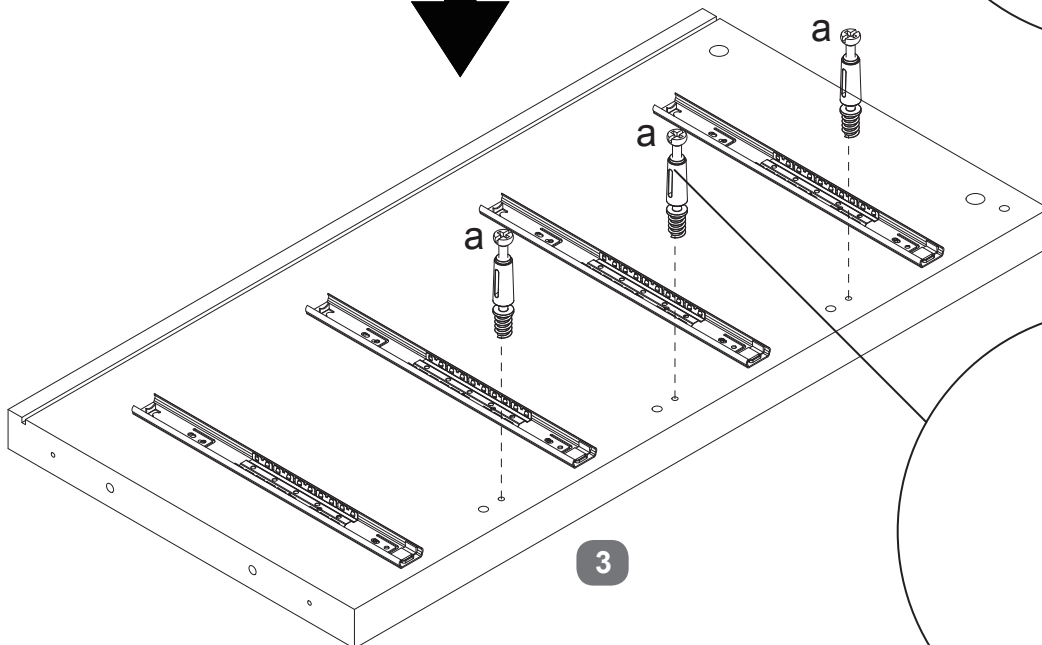
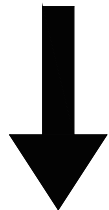
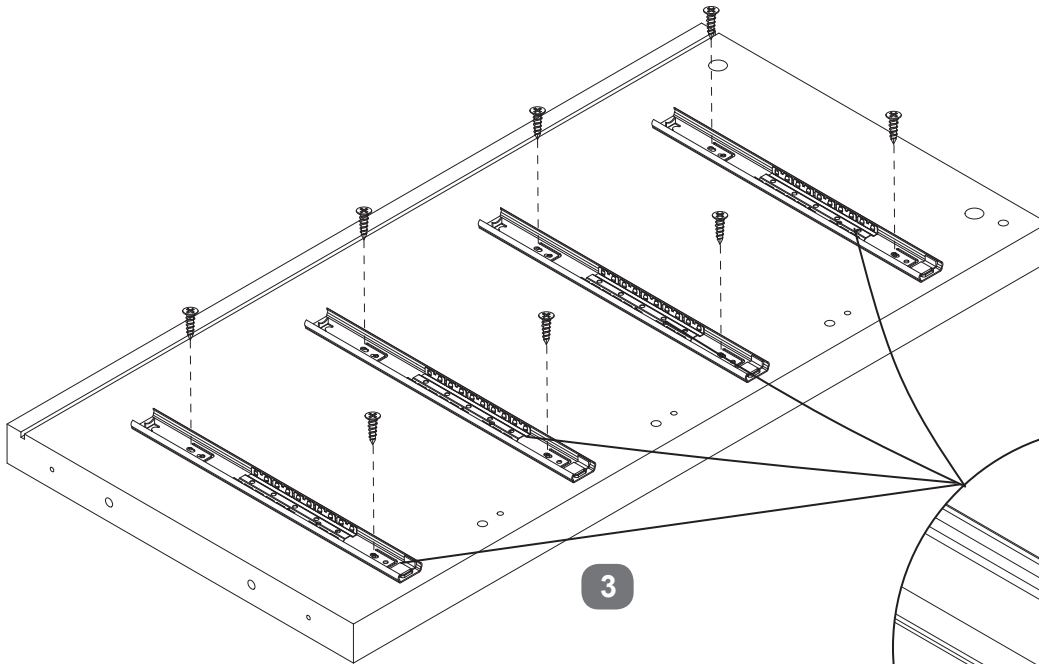

a		3	
h		8	
m-1		4	

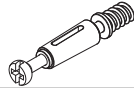

Cabinet Assembly

Stage
4

a		14	
e		8	

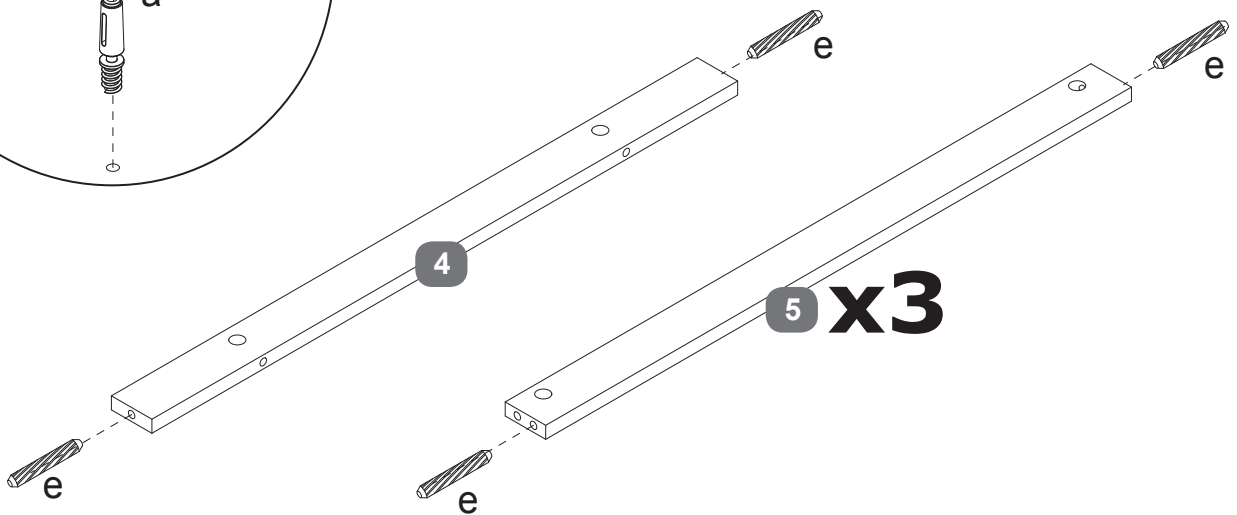
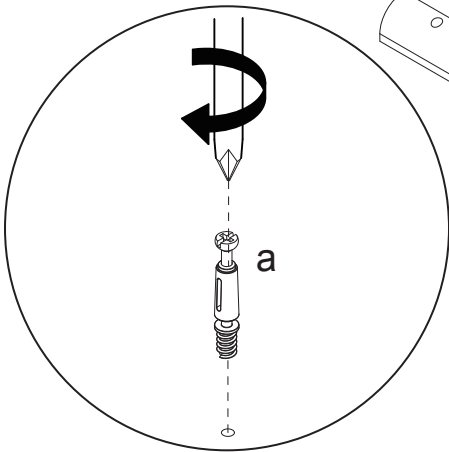
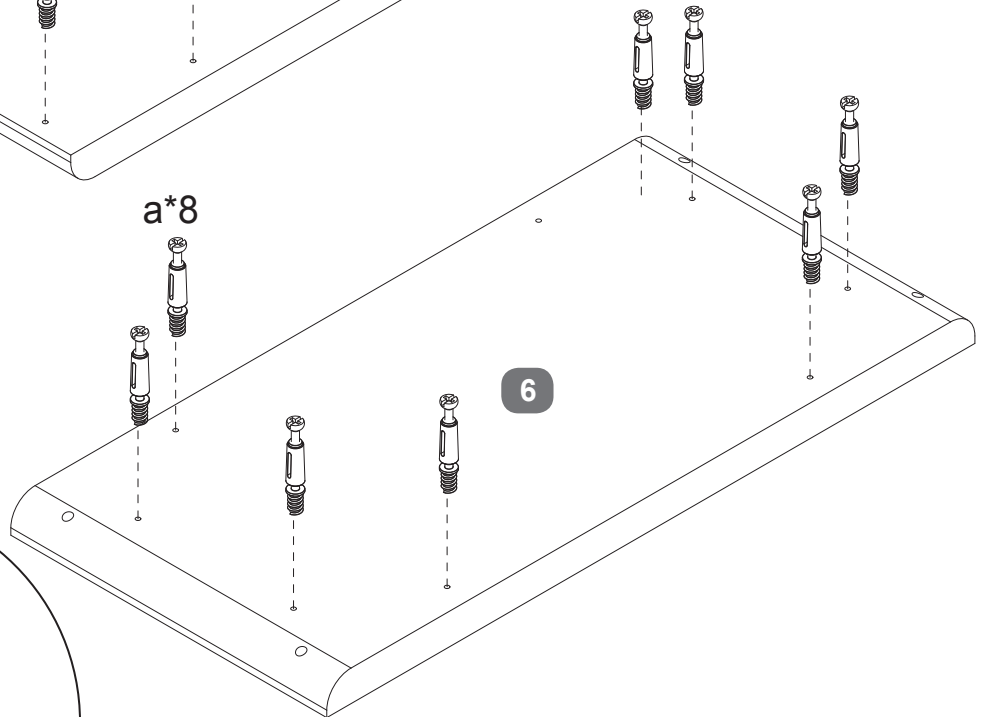
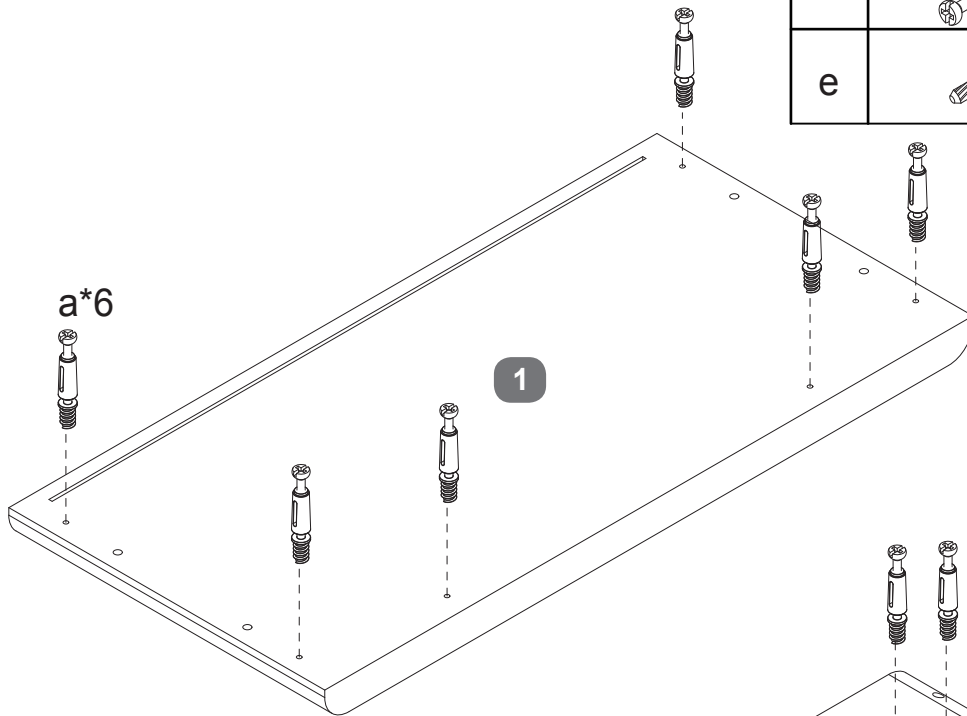

Cabinet Assembly

Stage
5

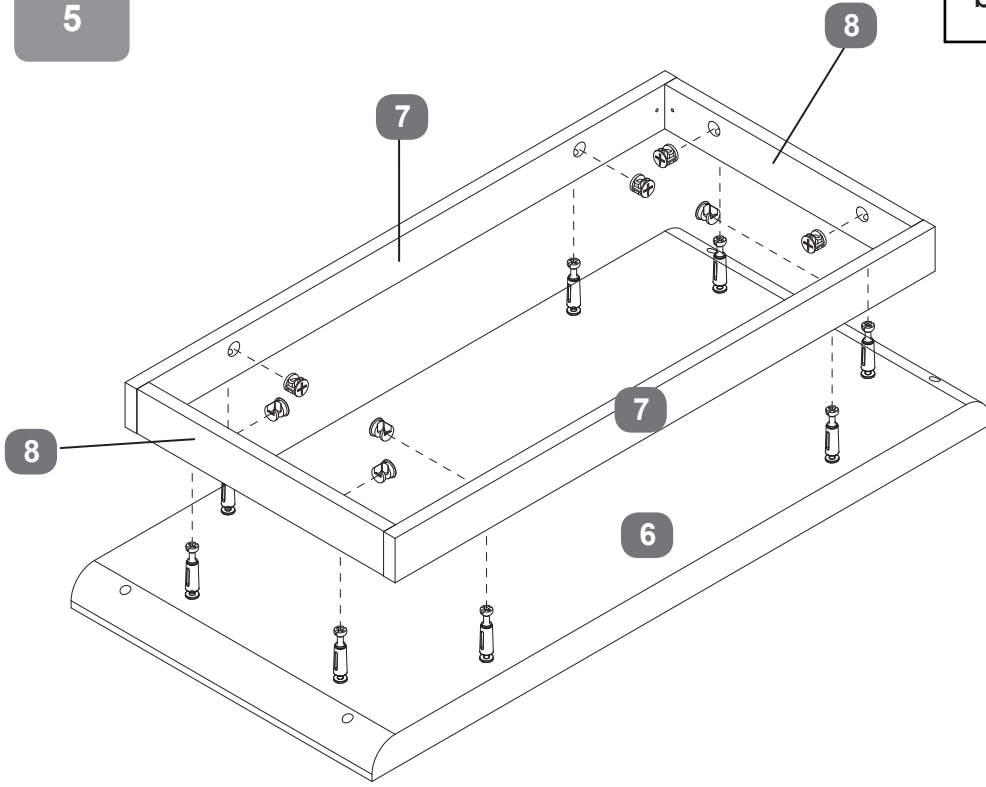

b		8	
---	--	---	--

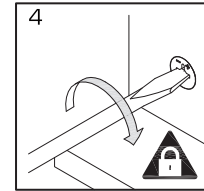
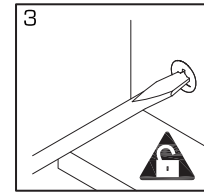
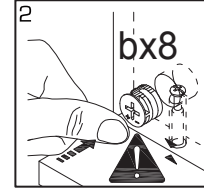
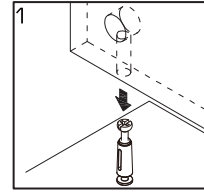

Stage
6

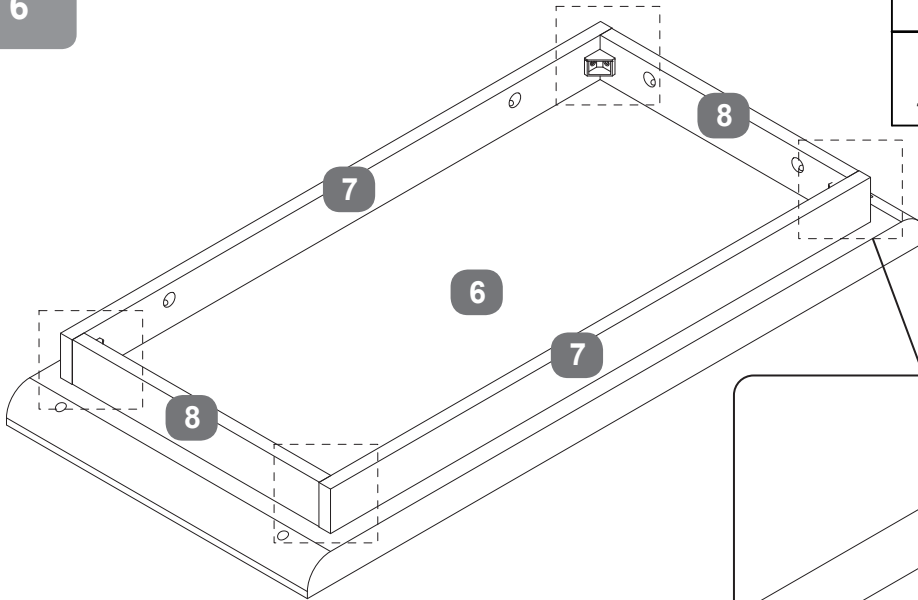

n		4	
j		8	

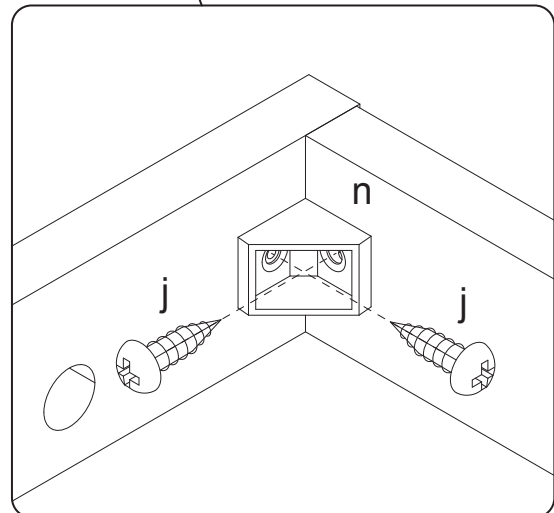

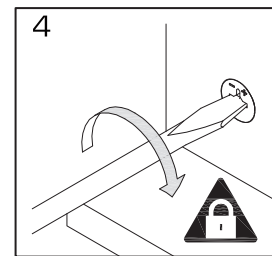
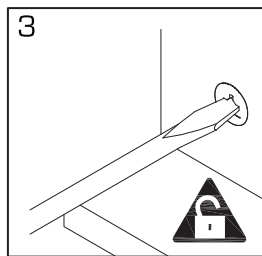
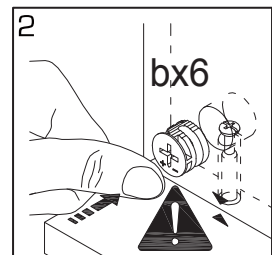
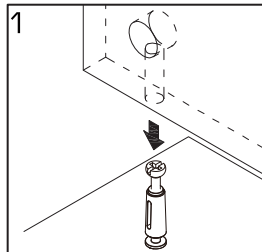
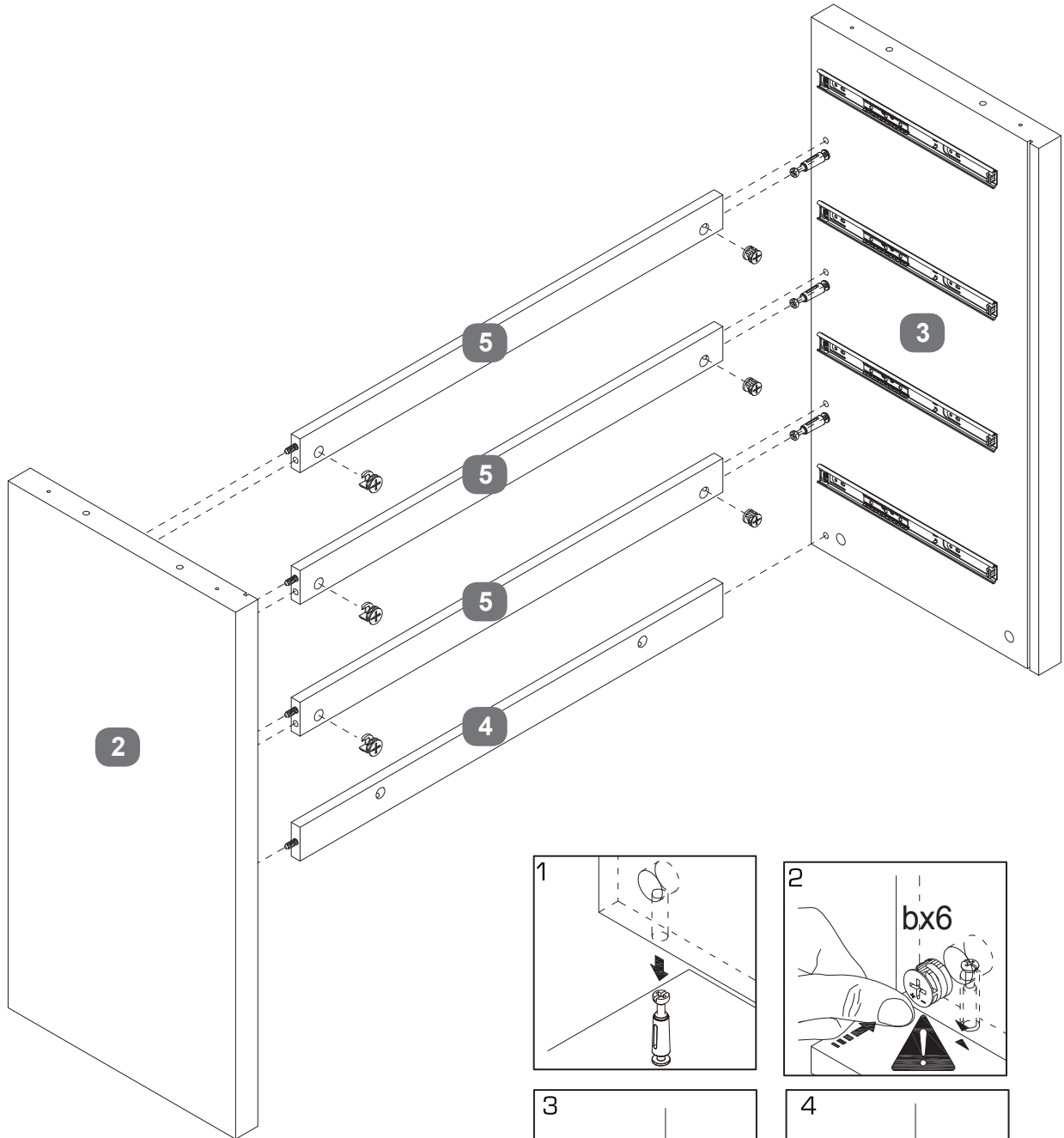

Cabinet Assembly

Stage
7



Cabinet Assembly

Stage
8

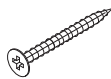
e		4	
f		4	

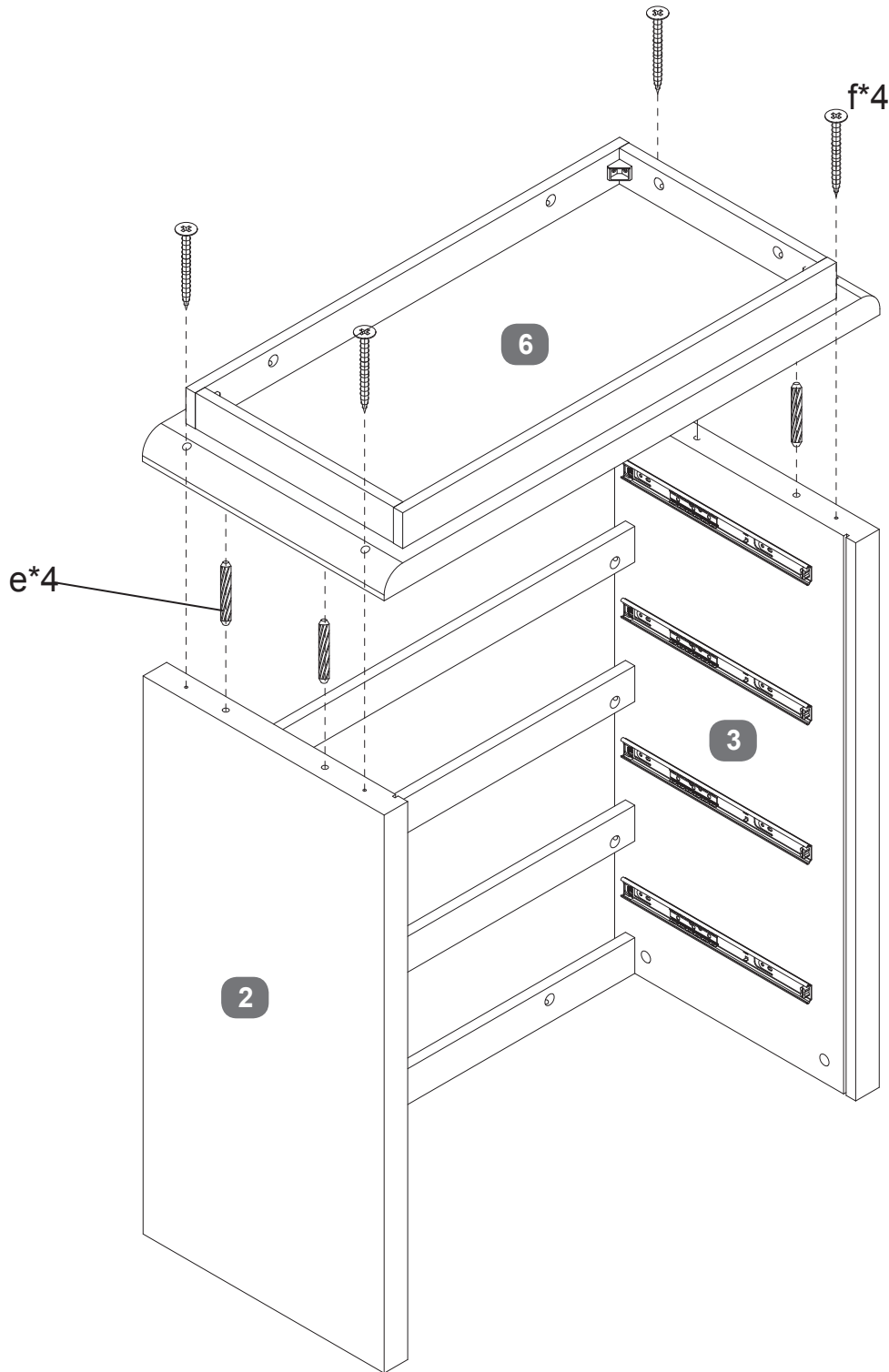

Cabinet Assembly

Stage
9

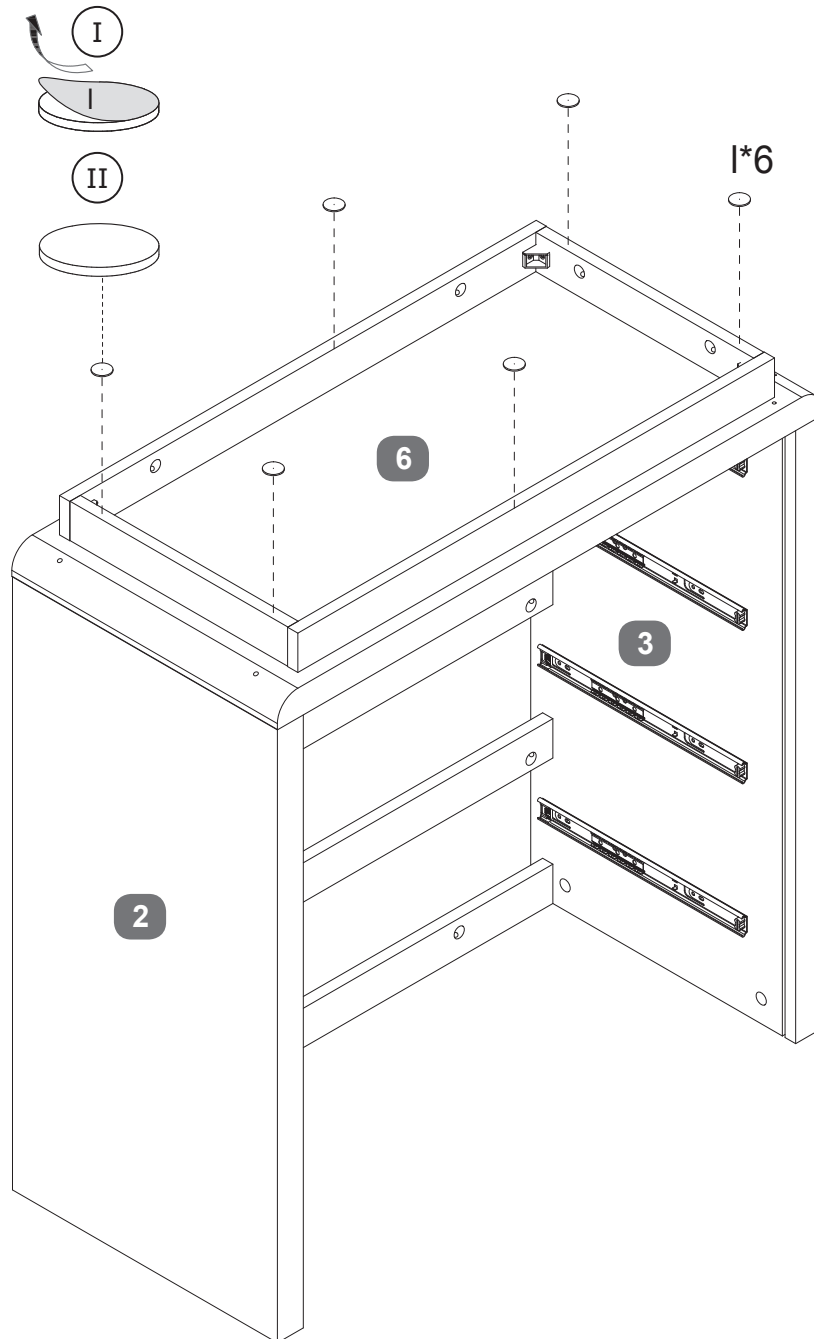

I		6	
---	-------------------------------------------------------------------------------------	---	--

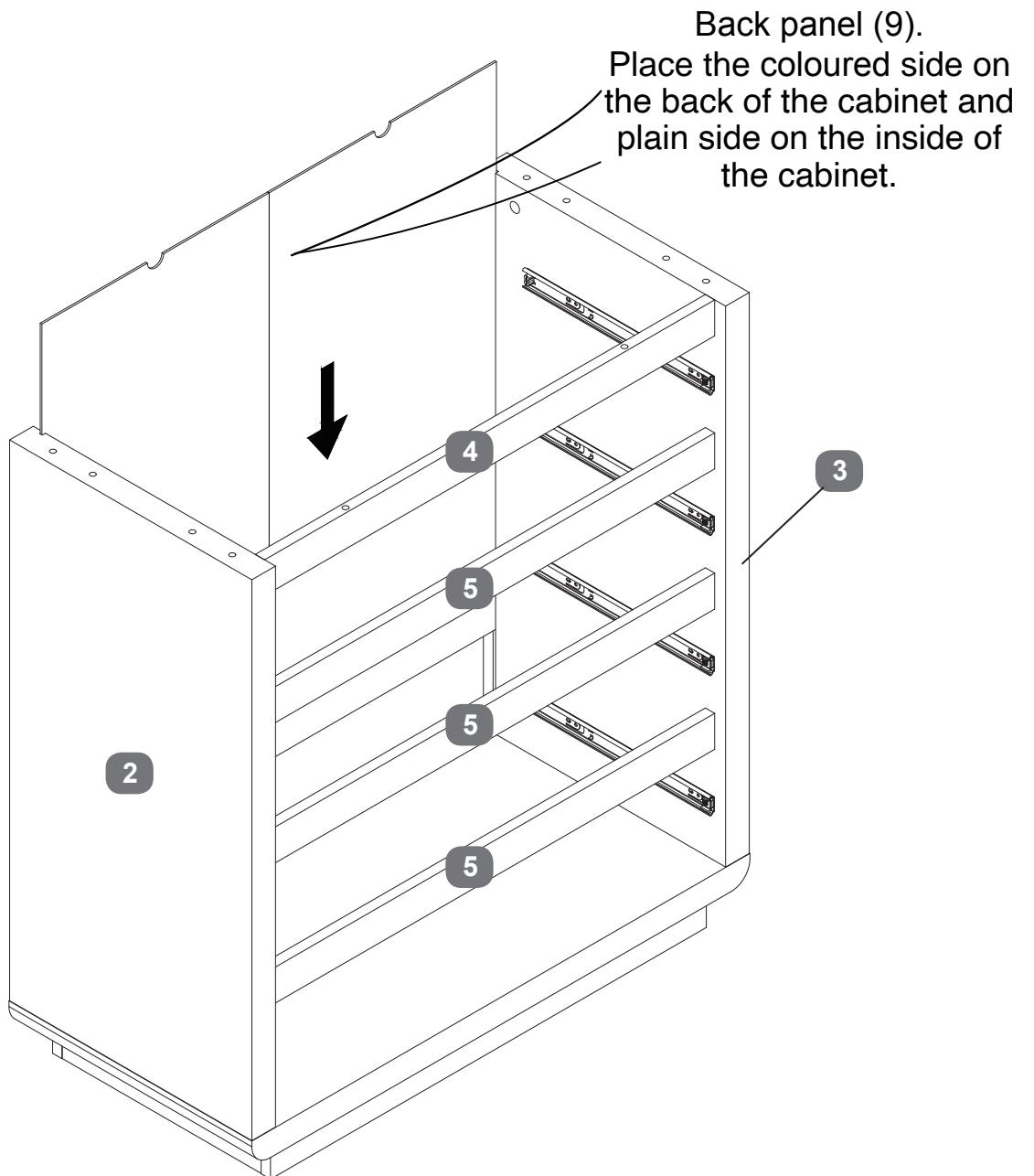



Cabinet Assembly

Stage
11

b		6	
e		4	

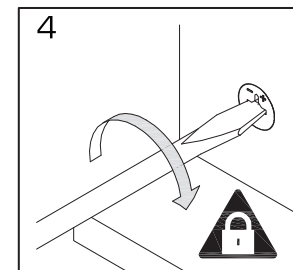
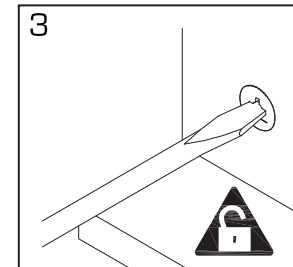
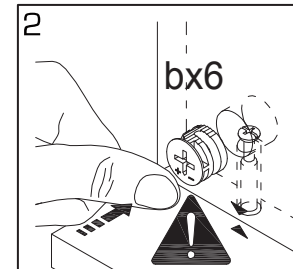
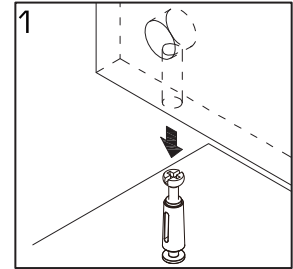
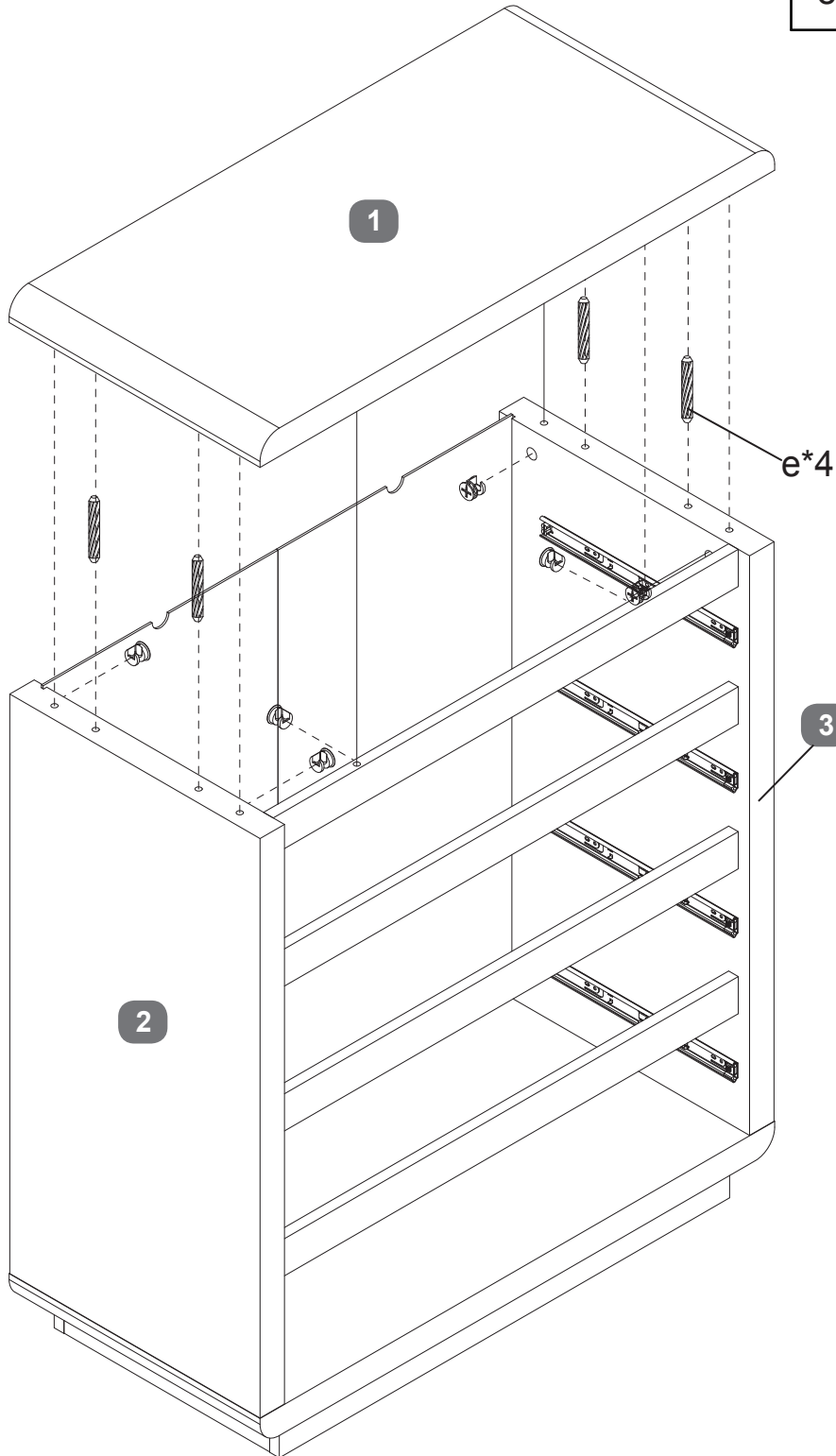

Cabinet Assembly

Stage
12

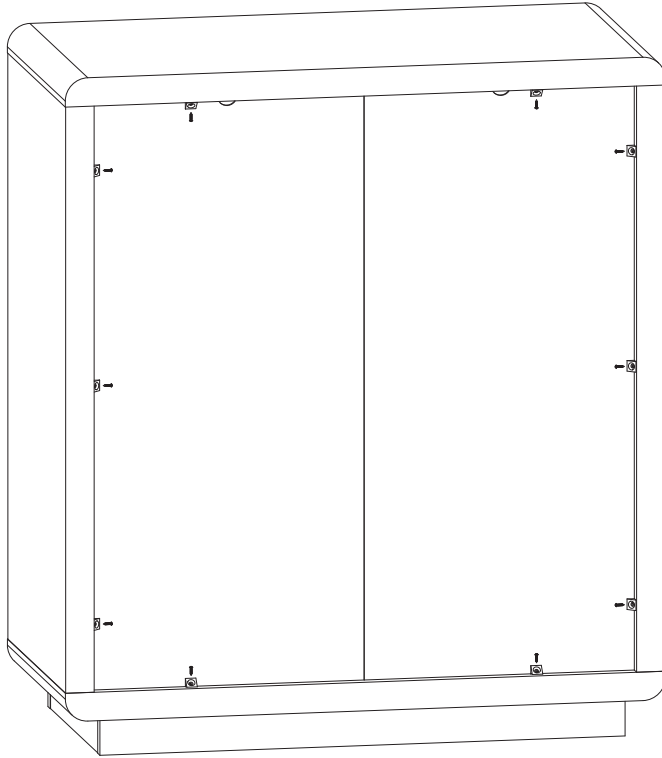

r		10	
s		10	

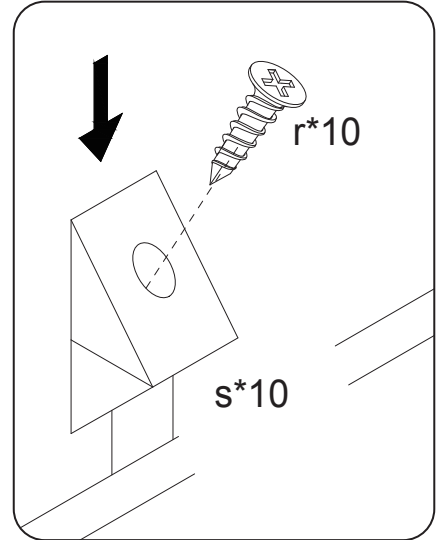

Stage
13

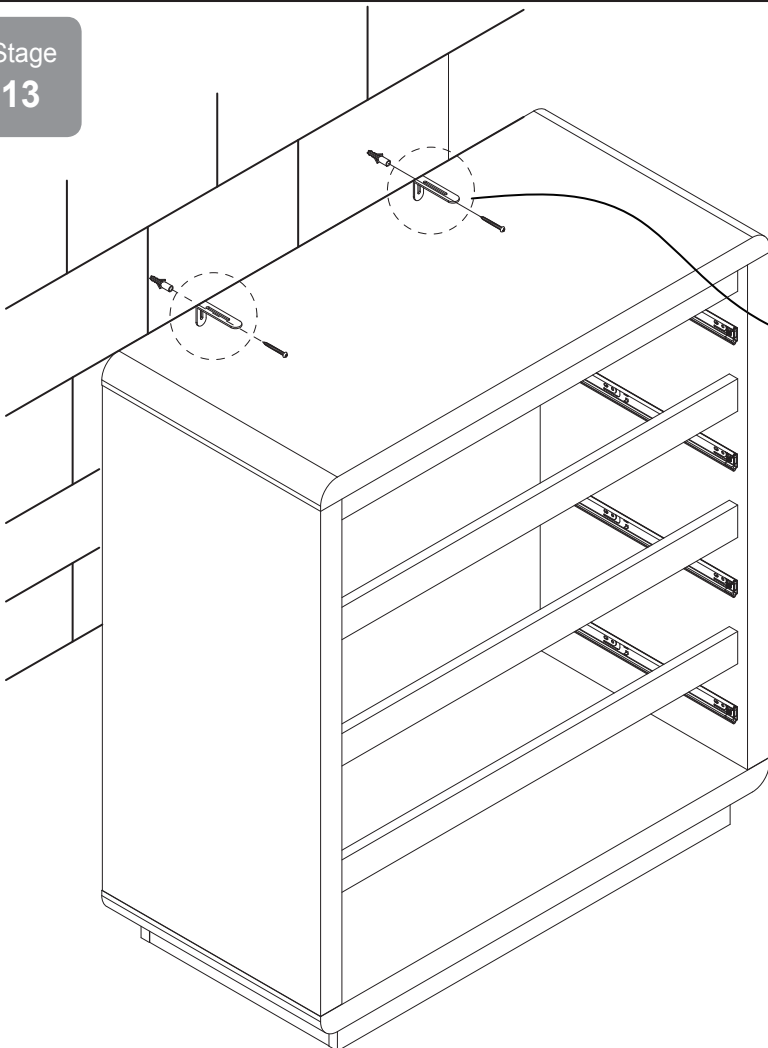

g		2	
k		2	
p		2	
q		2	

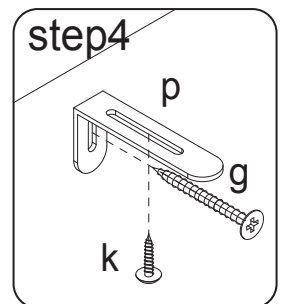
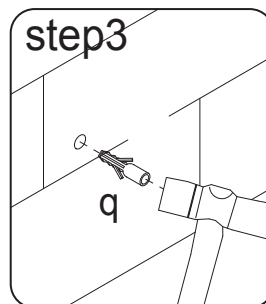
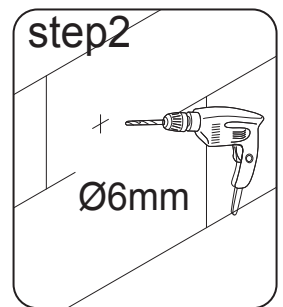
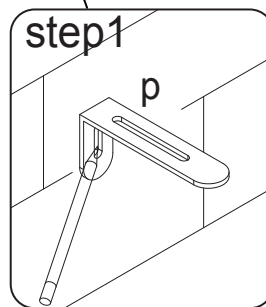

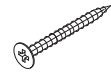

Stage
14

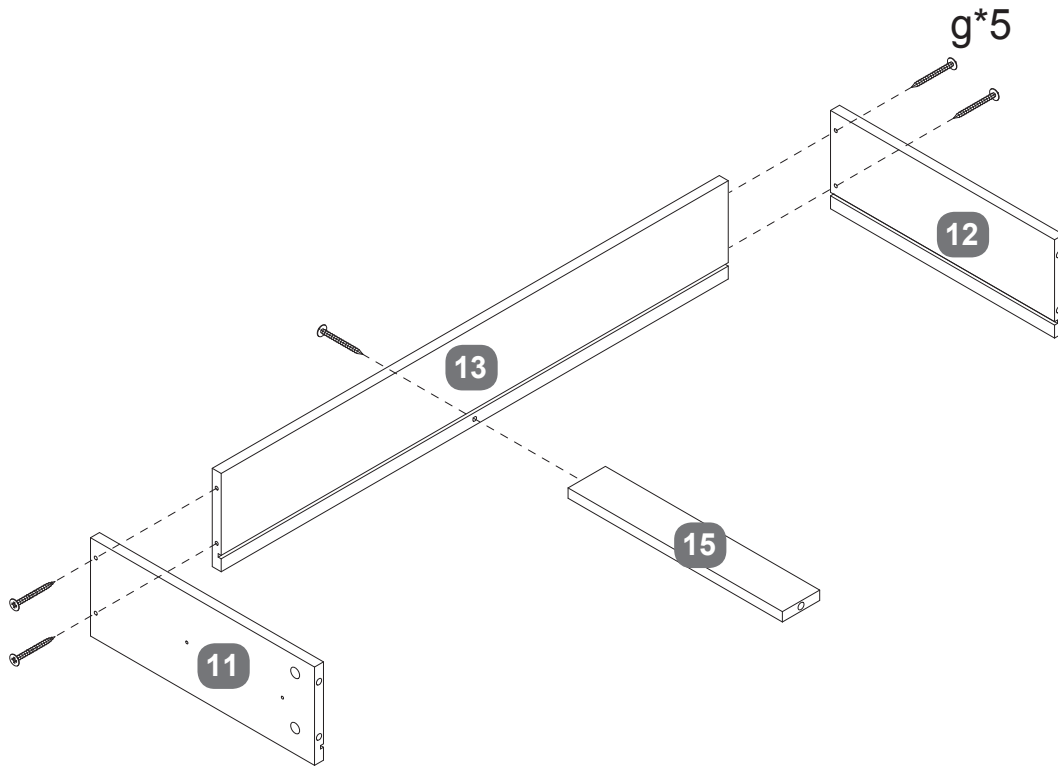

x4

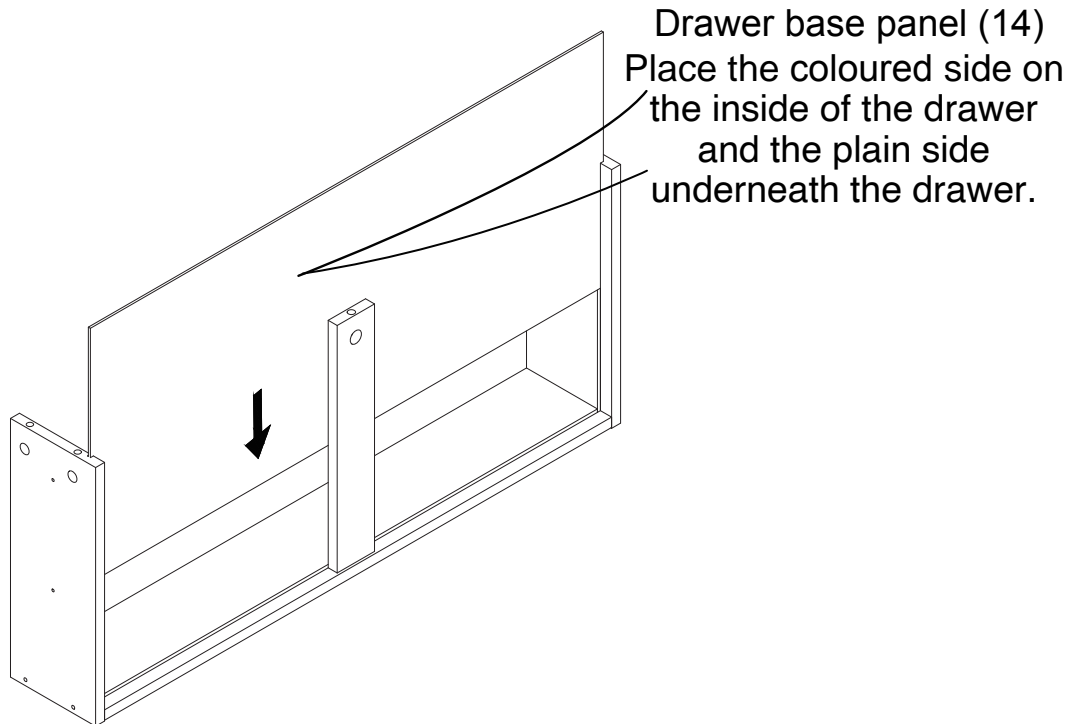

Stage
15



x4

Cabinet Assembly

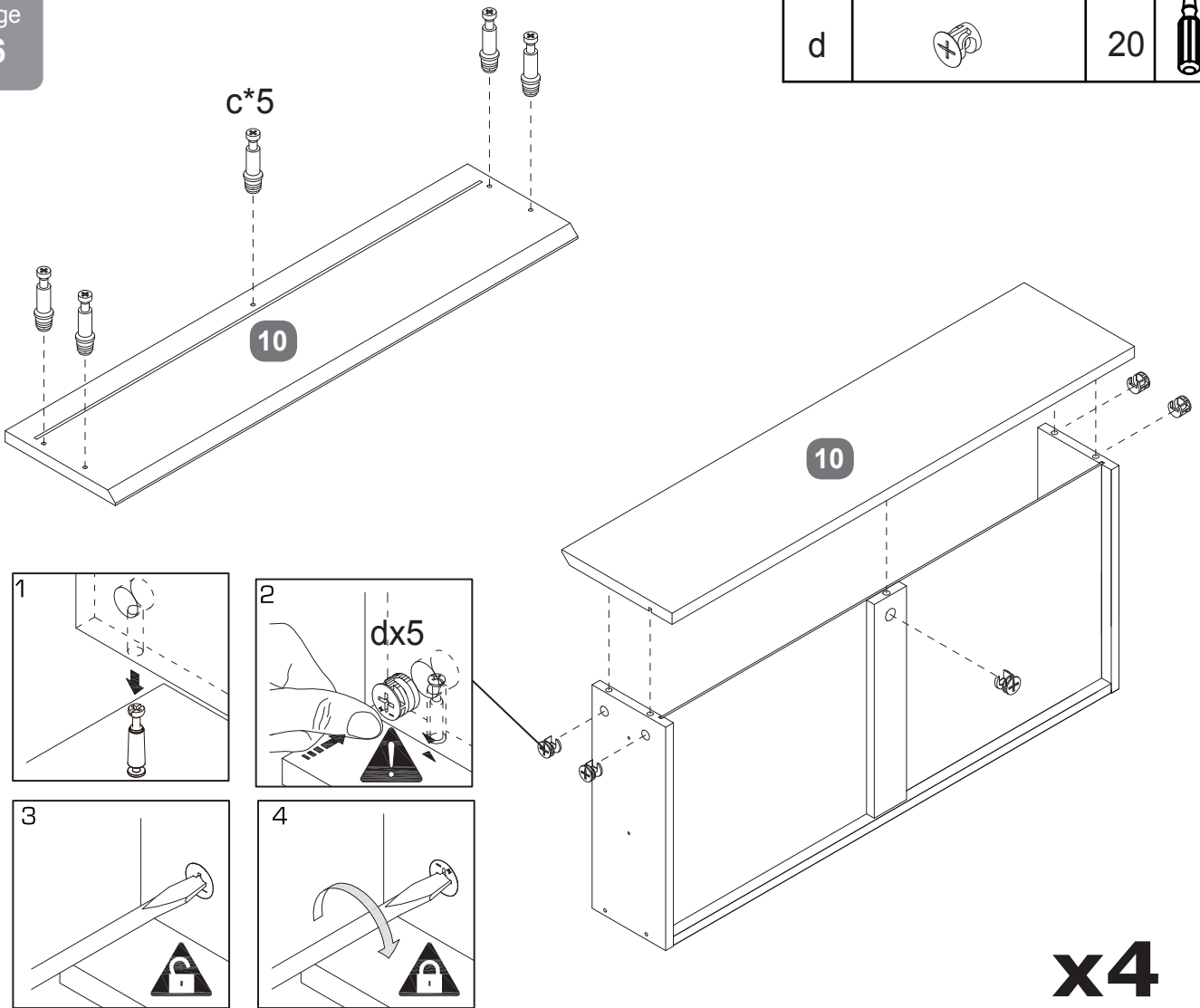

Stage
16

c		20	
d		20	



Stage
17

inner drawer slide (m-2)

h		16	
m-2		8	

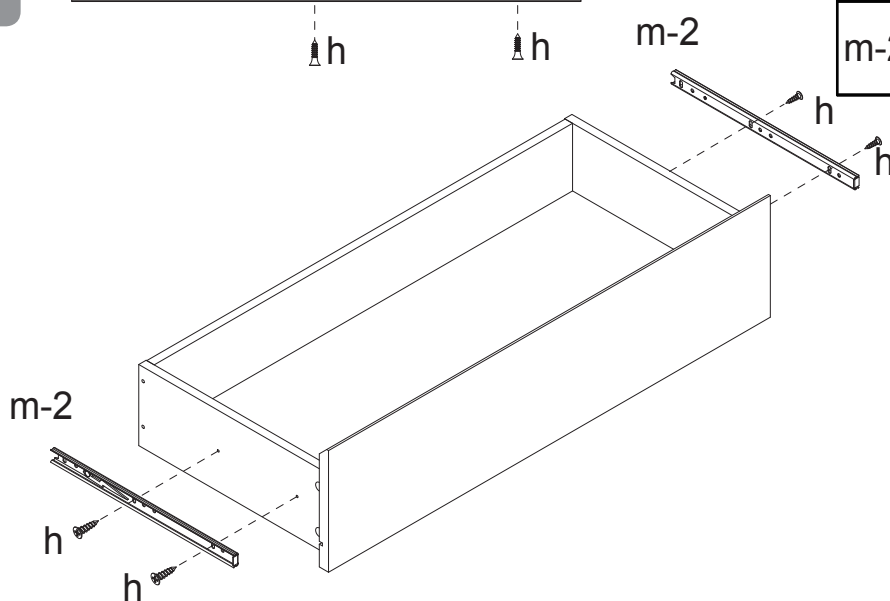

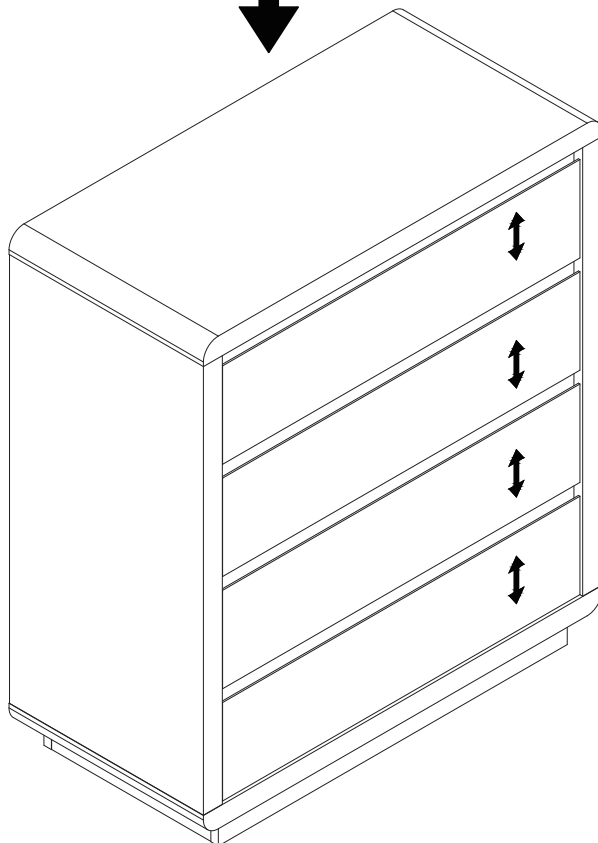
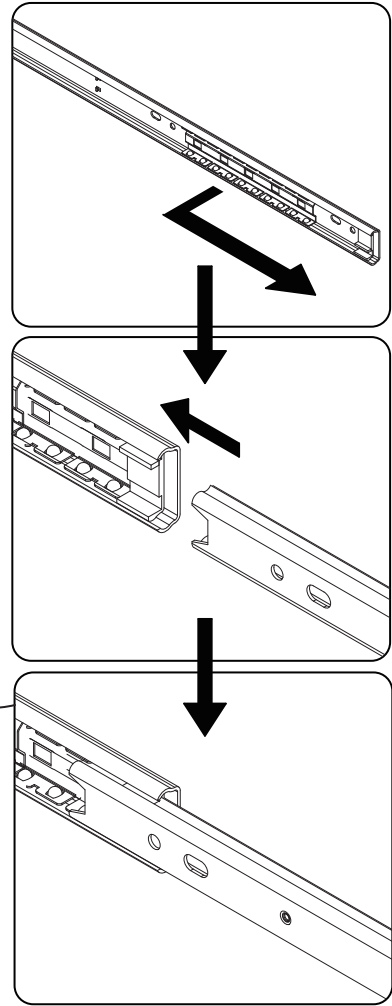
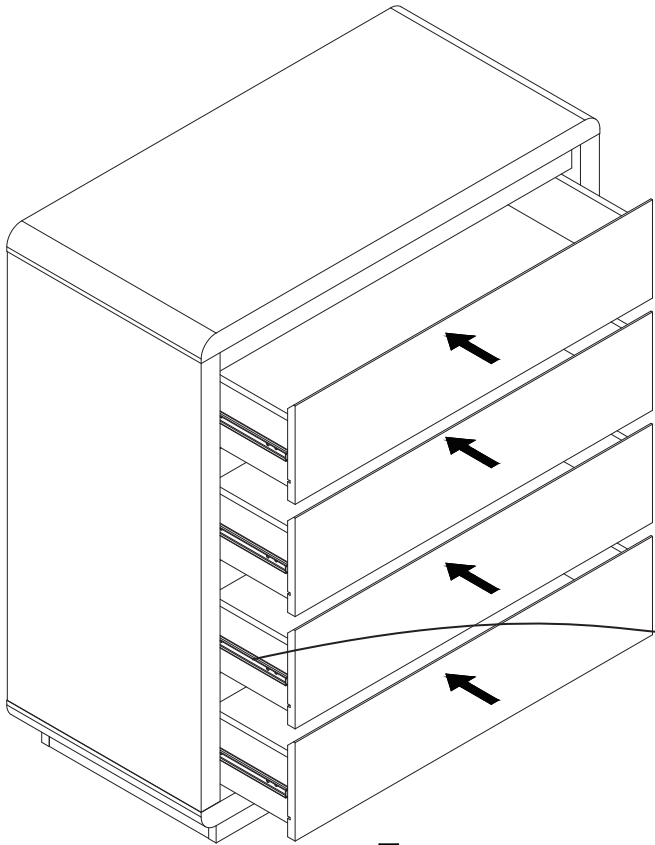

Cabinet Assembly

Stage
18



Cabinet Assembly

Stage
19

h		16	
---	-------------------------------------------------------------------------------------	----	-------------------------------------------------------------------------------------

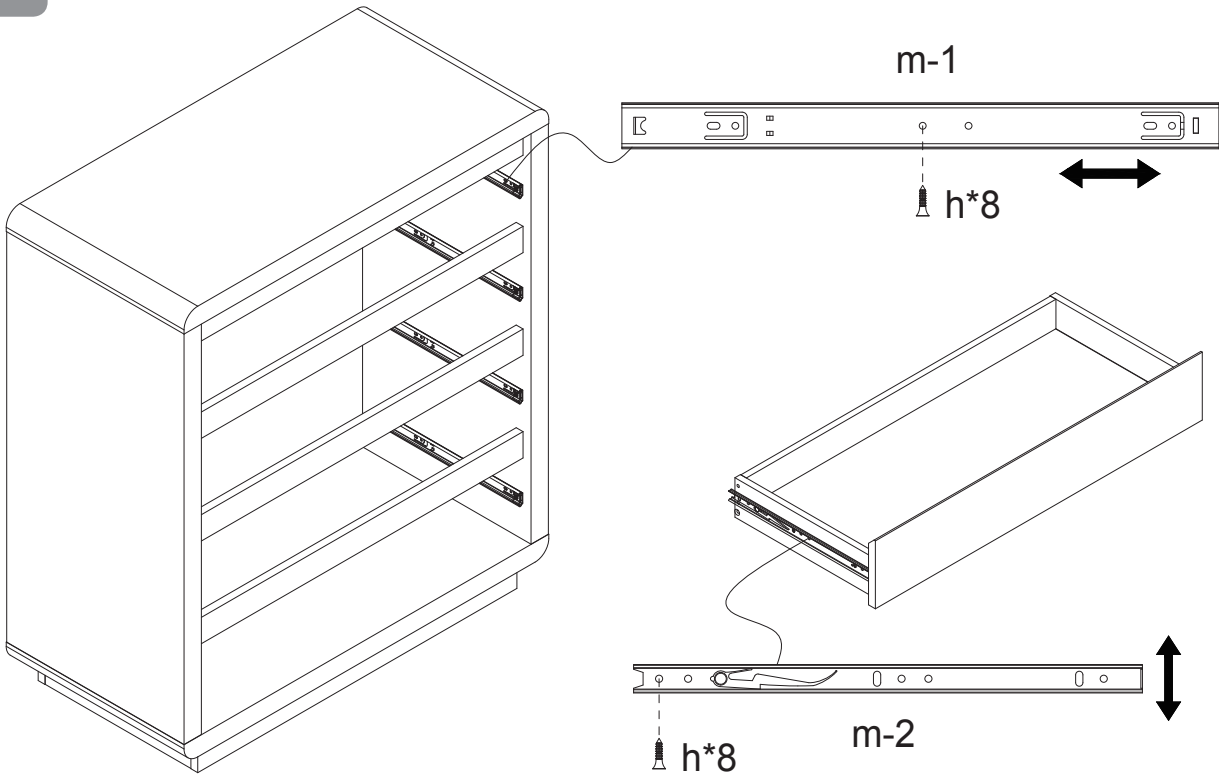

Stage
20

